

# WOOD STAIRS, COMBUSTIBLE MATERIAL ALLOWED DESIGN INTERIOR / EXTERIOR, WOOD FRAMED, PERMA-TREAD CLOSED RISERS, STAIR TREADS ARE PERMA-TREAD (PT)

STRINGERS: PERMA-TREAD 412 OR WOOD 4X12  
TREADS: PT 212 OR 312 SUPPORTED BY PERMA-TREAD 28 RISER  
RISERS: PERMA-TREAD 28 CLOSES THE RISERS  
LANDING/PLATFORM: PERMA-TREAD TG210 OR 212 AS PLANK, SPAN SUPPORTED BY JOIST

\* MUST REVIEW BUILDING TYPE FOR ACCEPTABLE STAIR FRAME CONSTRUCTION  
\* MUST ENGINEER CONNECTIONS, STAIR FRAME, LANDING FRAME TO MEET LOAD REQUIREMENTS

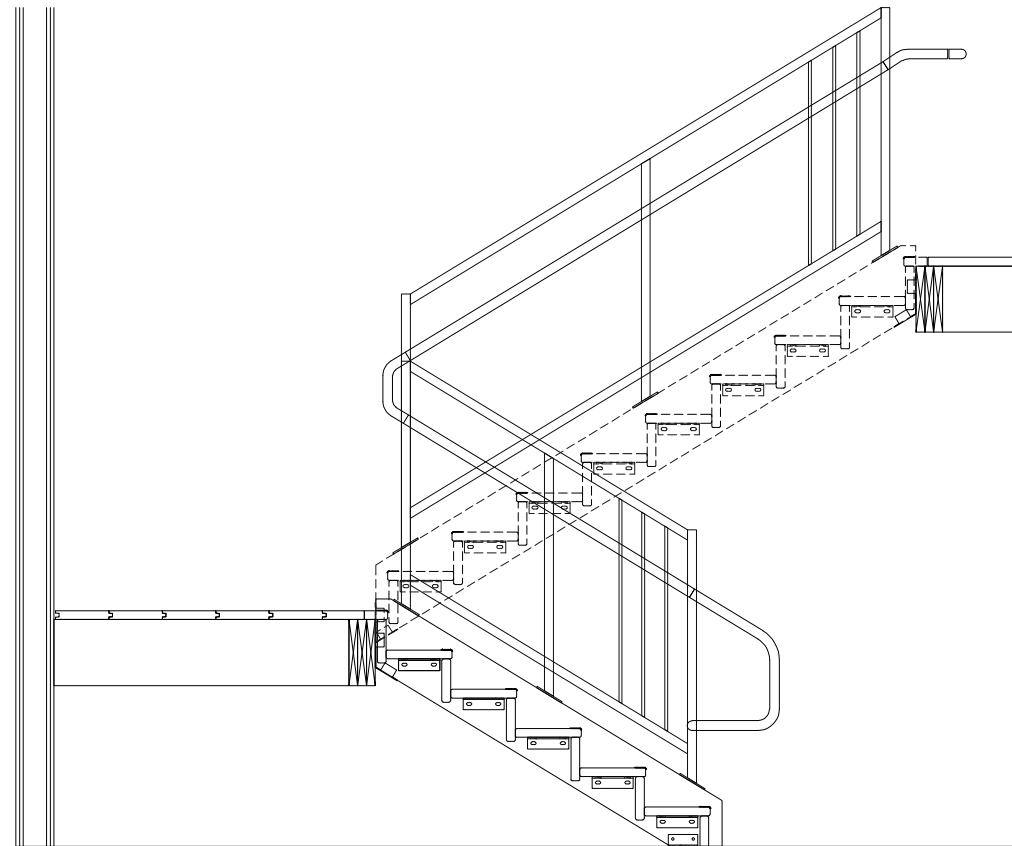

A-1 ELEVATION VIEW

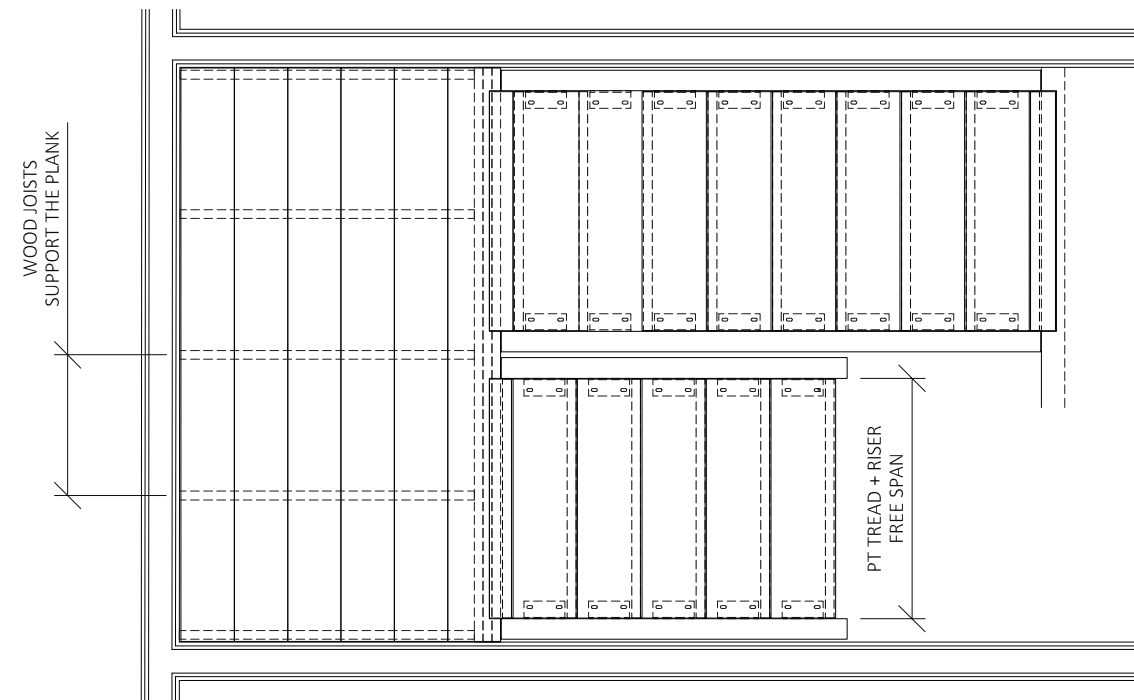

A-2 TOP VIEW

ASTM E648 TYPE 1, ASTM E84 CLASS B FIRE RATING  
(PERMA-TREAD EXPOSED TO FLAME)

DETAIL 9-10 WHERE STAIR STRUCTURE PERMITTED TO BE CONSTRUCTED WITH COMBUSTIBLE MATERIAL

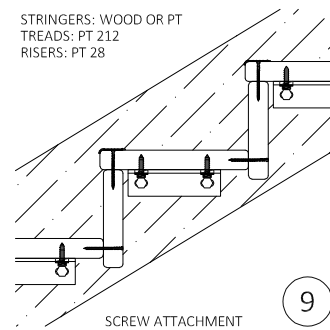

9

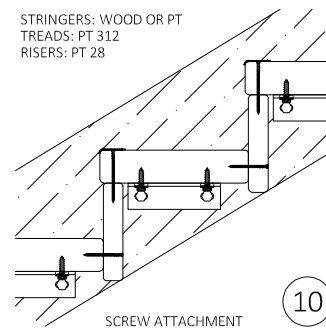

10

METAL STAIR NOSINGS  
NON-SLIP CONTRASTING STRIPE  
MFG.: SAFE-T-NOSE  
PART #: STNR

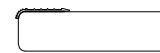

ADHESIVE ATTACHMENT  
AND/OR  
SCREW ATTACHMENT

A-A

(971) 772-4553 | sales@nationalstair.com | www.nationalstair.com

PERMA-TREAD / WOOD FRAMED STAIR  
PERMA-TREAD STRINGERS, RISERS, TREADS



SCALE: N.T.S.

DWG #: PT-3.5

# WOOD STAIRS, COMBUSTIBLE MATERIAL ALLOWED DESIGN INTERIOR / EXTERIOR, WOOD FRAMED, PERMA-TREAD CLOSED RISERS, STAIR TREADS ARE PERMA-TREAD (PT)

STRINGERS: PERMA-TREAD 212 OR WOOD 2X12  
TREADS: PT 212 OR 312 SUPPORTED BY PERMA-TREAD 28 RISER  
RISERS: PERMA-TREAD 28 CLOSES THE RISERS  
LANDING/PLATFORM: PERMA-TREAD TG210 OR 212 AS PLANK, SPAN SUPPORTED BY JOIST

\* MUST REVIEW BUILDING TYPE FOR ACCEPTABLE STAIR FRAME CONSTRUCTION  
\* MUST ENGINEER CONNECTIONS, STAIR FRAME, LANDING FRAME TO MEET LOAD REQUIREMENTS

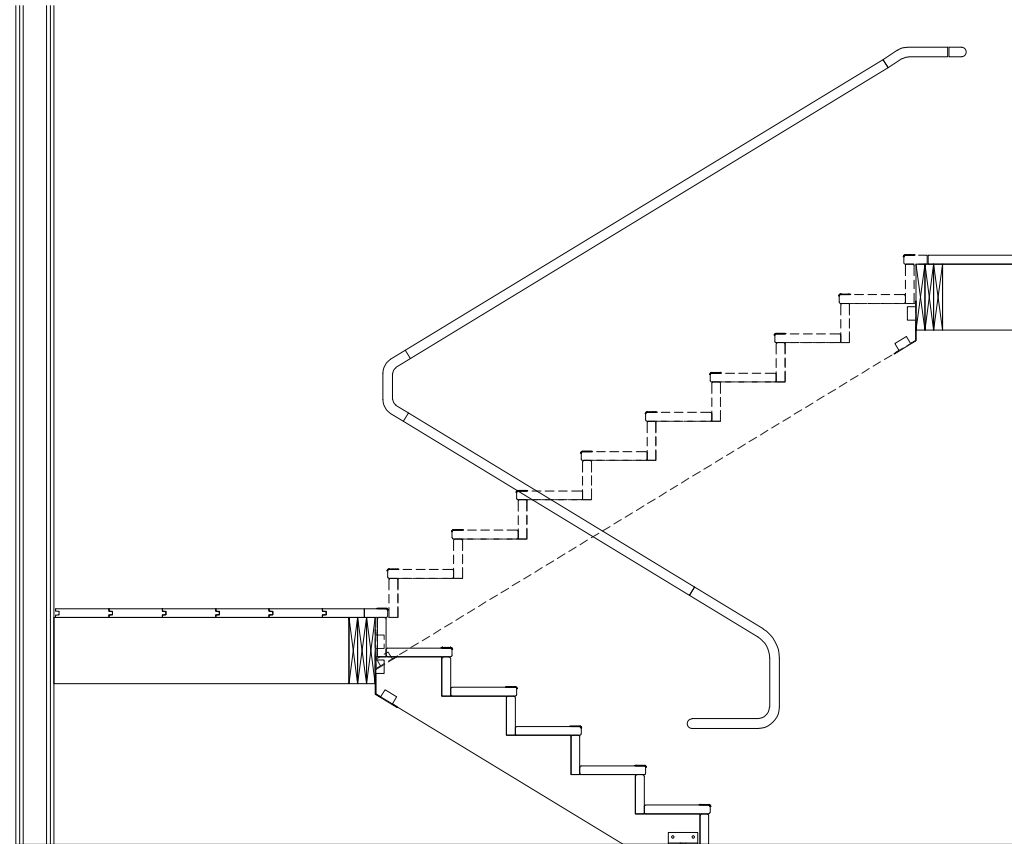

A-1 ELEVATION VIEW

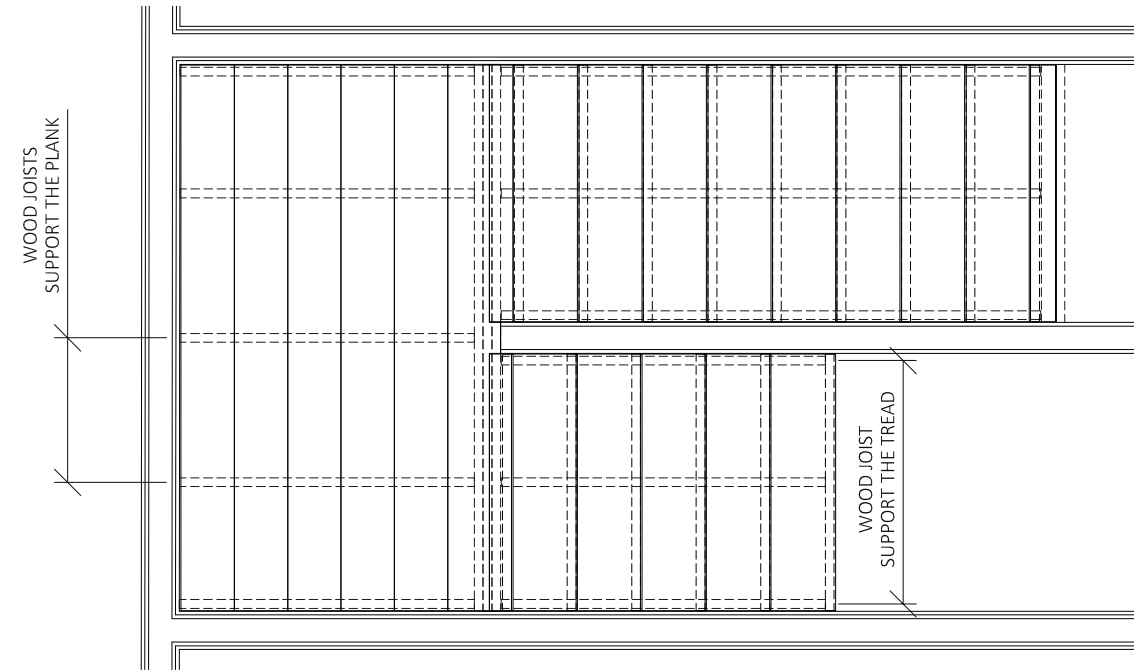

A-2 TOP VIEW

ASTM E648 TYPE 1, ASTM E84 CLASS B FIRE RATING  
(PERMA-TREAD EXPOSED TO FLAME)

DETAIL 11-12 WHERE STAIR STRUCTURE PERMITTED TO BE CONSTRUCTED WITH COMBUSTIBLE MATERIAL

STRINGERS: WOOD OR PT  
TREADS: PT 212  
RISERS: PT 28

SCREW ATTACHMENT

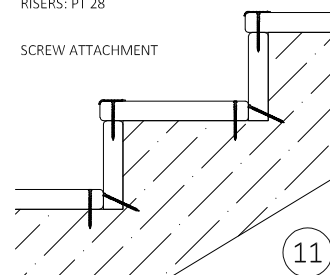

11

STRINGERS: WOOD OR PT  
TREADS: PT 312  
RISERS: PT 28

SCREW ATTACHMENT

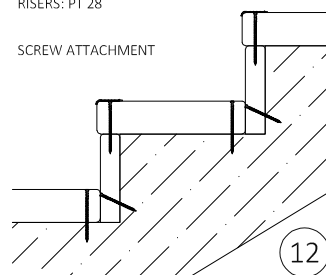

12

METAL STAIR NOSINGS  
NON-SLIP CONTRASTING STRIPE  
MFG.: SAFE-T-NOSE  
PART #: STNR



ADHESIVE ATTACHMENT  
AND/OR  
SCREW ATTACHMENT

A-A

**PERMA-TREAD™**

(971) 772-4553 | sales@nationalstair.com | www.nationalstair.com

PERMA-TREAD / WOOD FRAMED STAIR  
PERMA-TREAD STRINGERS, RISERS, TREADS



SCALE: N.T.S.

DWG #: PT-3.6