

# PRE-FABRICATED METAL FRAME, FIRE RATED DESIGN, PERMA-TREAD FULLY PROTECTED FROM FLAME INTERIOR / EXTERIOR, METAL FRAMED, METAL CLOSED RISERS, STAIR TREADS ARE PERMA-TREAD (PT)

STRINGERS: METAL  
 TREADS: PT 212 OR 312 FULLY SUPPORTED & PROTECTED BY METAL FLAT PAN  
 RISERS: METAL FLAT PAN CLOSES THE RISERS  
 LANDING/PLATFORM: PT 212 AS PLANK, FULLY SUPPORTED & PROTECTED BY METAL

\* MUST REVIEW BUILDING TYPE FOR ACCEPTABLE STAIR FRAME CONSTRUCTION  
 \* MUST ENGINEER CONNECTIONS, STAIR FRAME, METAL PANS, LANDING FRAME TO MEET LOAD REQUIREMENTS

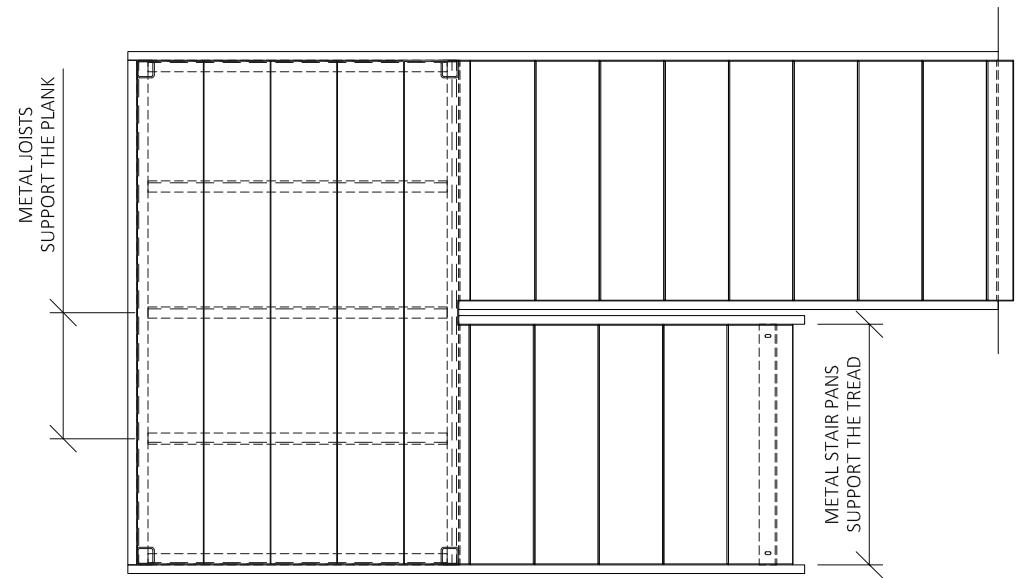

A-2 TOP VIEW

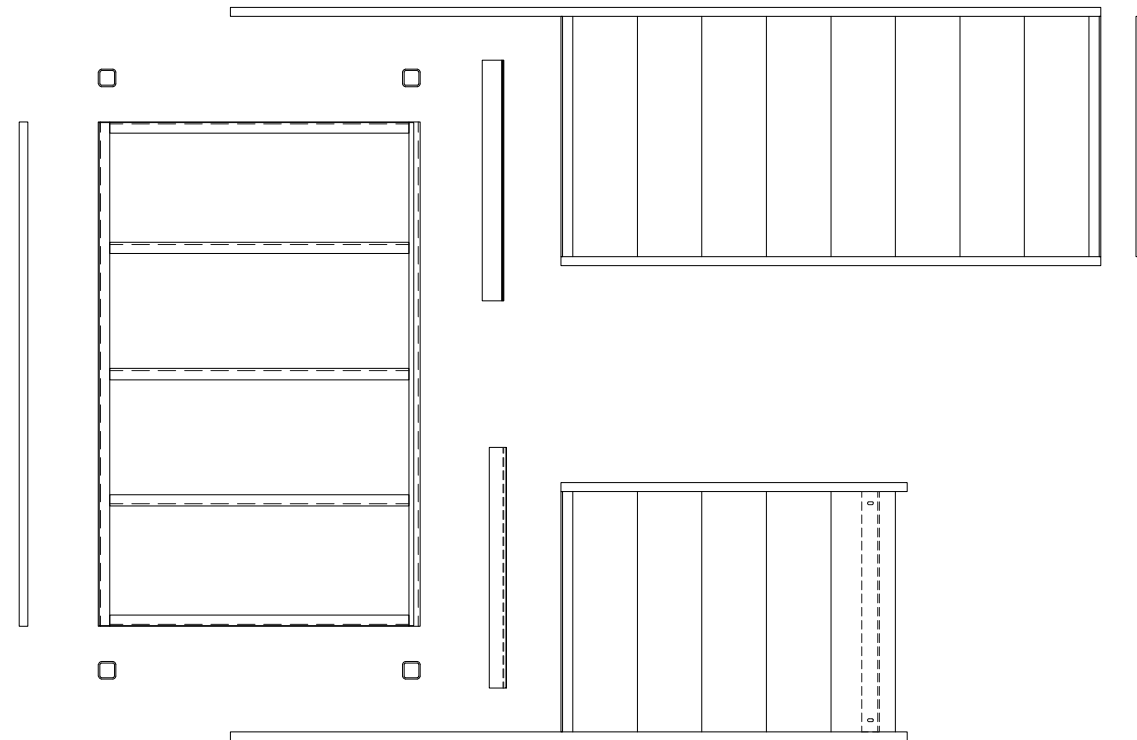

A-3 METAL FRAME BREAK DOWN  
 (RAILS SHIPPED LOOSE)

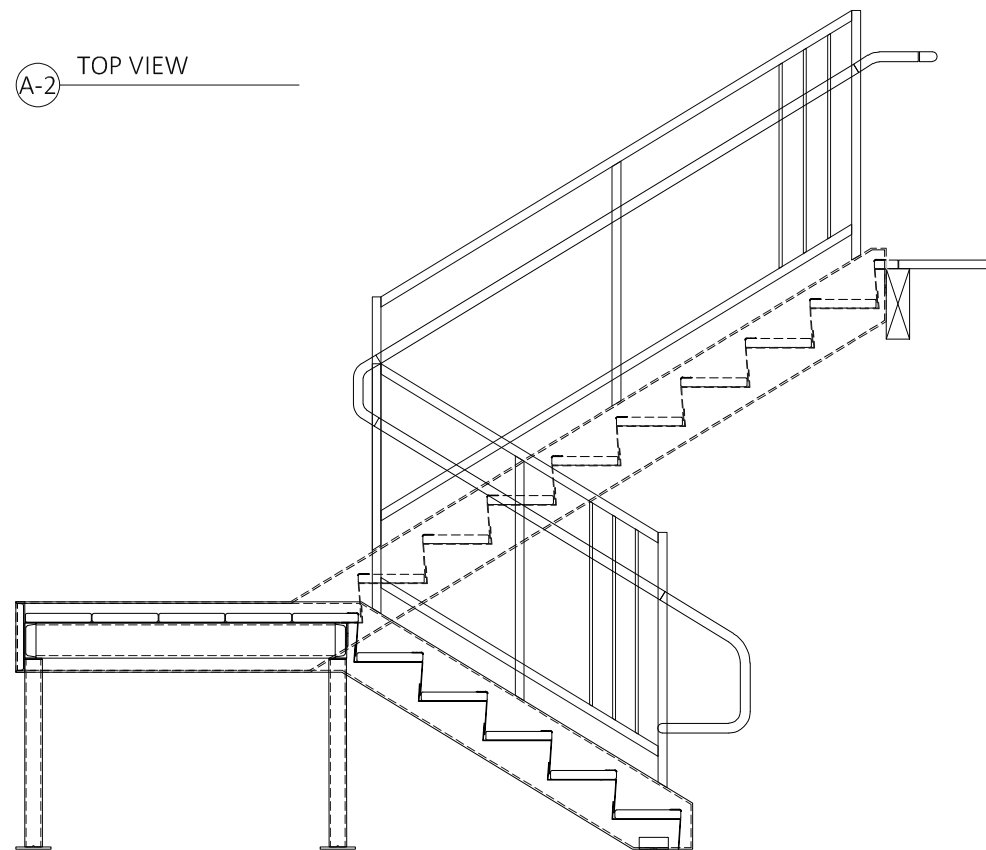

A-1 ELEVATION VIEW

ASTM E648 TYPE 1, ASTM E84 CLASS A FIRE RATING  
 (PERMA-TREAD SERVING AS FLOOR FINISH, FULLY PROTECTED BY METAL)

DETAIL 1-2 WHERE STAIR STRUCTURE SHALL BE NON-COMBUSTIBLE MATERIAL

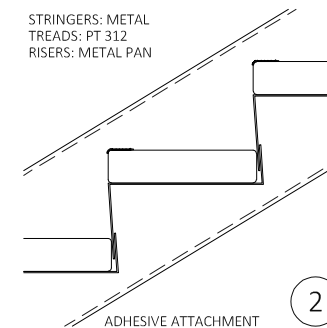
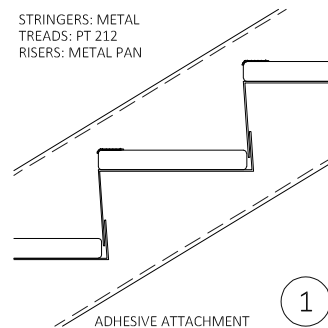

METAL STAIR NOSINGS  
 NON-SLIP CONTRASTING STRIPE  
 MFG.: SAFE-T-NOSE  
 PART #: STNR

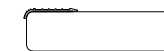

ADHESIVE ATTACHMENT  
 AND/OR  
 SCREW ATTACHMENT

A-A

**PERMA-TREAD™**

(971) 772-4553 | sales@nationalstair.com | www.nationalstair.com

PRE-FABRICATED METAL STAIR  
 METAL FLAT PAN CLOSED RISERS

0

SCALE: N.T.S.

DWG #: PT-3.1

# PRE-FABRICATED, FIRE RATED DESIGN, PERMA-TREAD FULLY PROTECTED FROM FLAME INTERIOR / EXTERIOR, METAL FRAMED, METAL CLOSED RISERS, STAIR TREADS ARE PERMA-TREAD (PT)

STRINGERS: METAL  
TREADS: PT 212 OR 312 FULLY SUPPORTED & PROTECTED BY METAL FLAT PAN  
RISERS: METAL FLAT PAN CLOSES THE RISERS  
LANDING/PLATFORM: PT 212 AS PLANK, FULLY SUPPORTED & PROTECTED BY METAL

\* MUST REVIEW BUILDING TYPE FOR ACCEPTABLE STAIR FRAME CONSTRUCTION  
\* MUST ENGINEER CONNECTIONS, STAIR FRAME, METAL PANS, LANDING FRAME TO MEET LOAD REQUIREMENTS

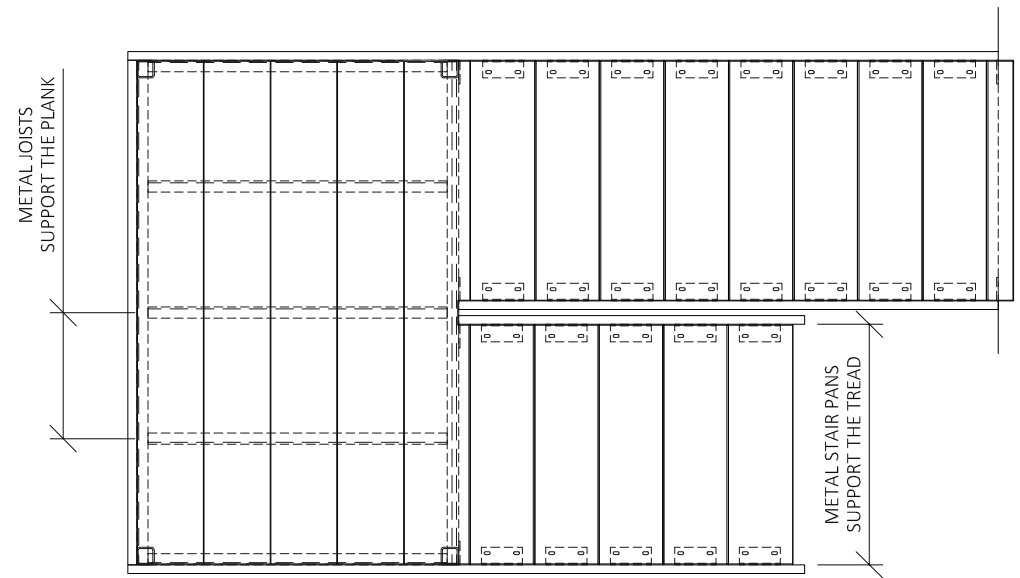

A-2 TOP VIEW

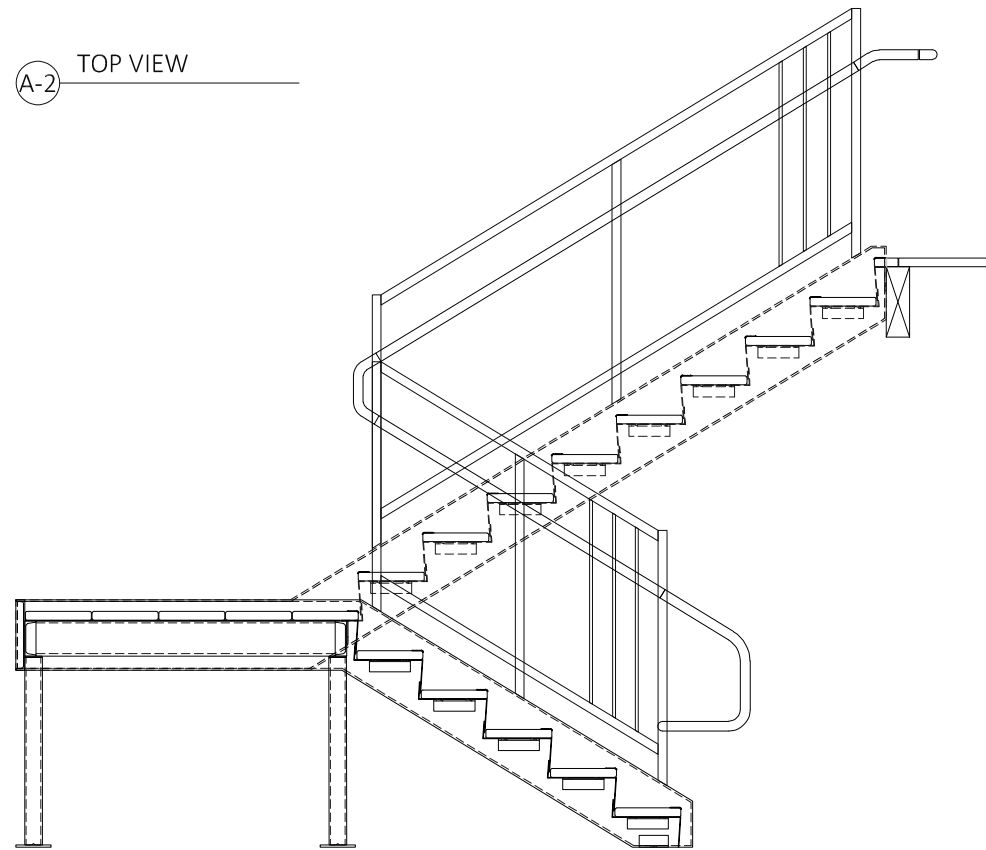

A-1 ELEVATION VIEW

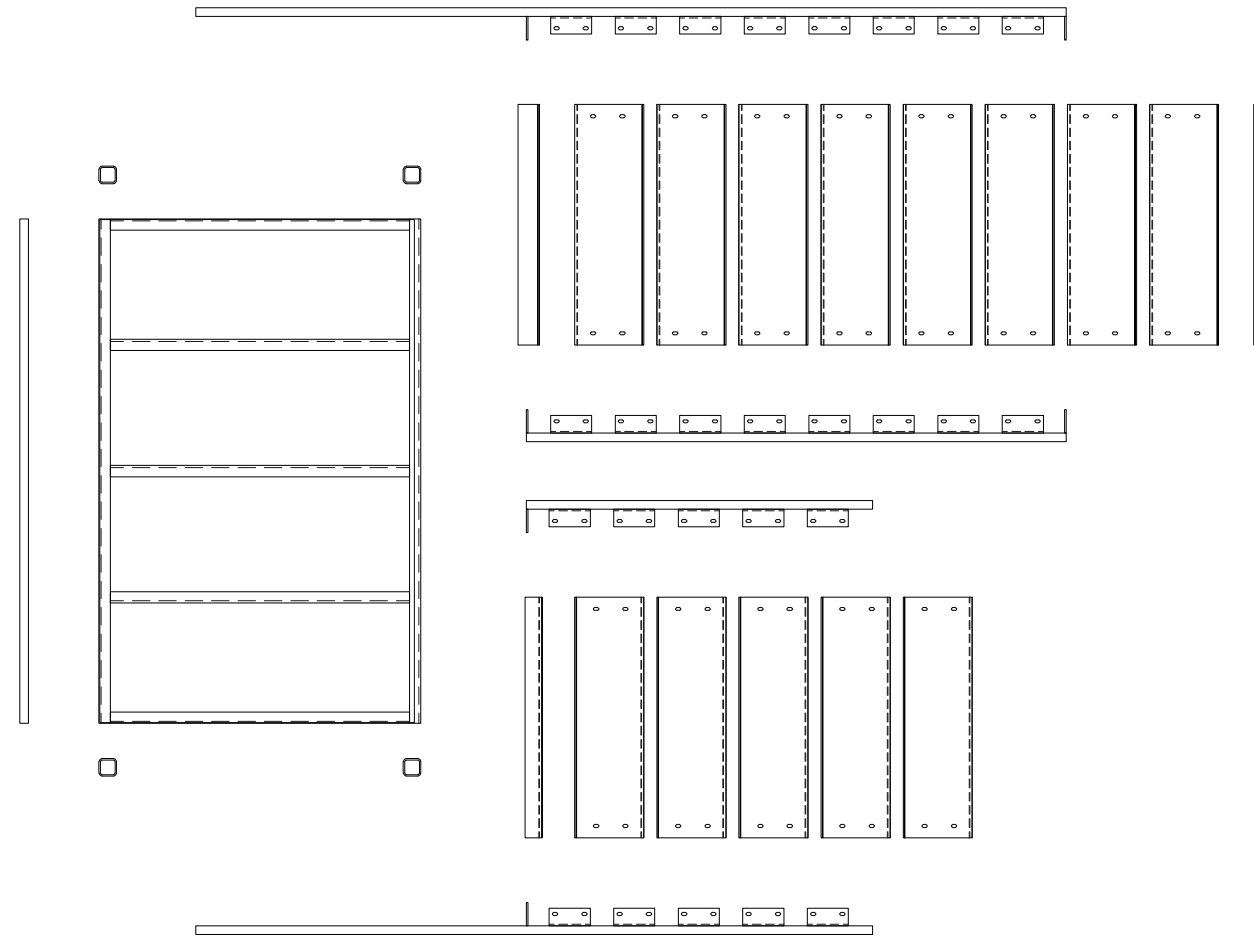

A-3 METAL FRAME BREAK DOWN  
(RAILS SHOP WELDED TO STRINGERS OPTIONAL)

ASTM E648 TYPE 1, ASTM E84 CLASS A FIRE RATING  
(PERMA-TREAD SERVING AS FLOOR FINISH, FULLY PROTECTED BY METAL)

DETAIL 3-4 WHERE STAIR STRUCTURE SHALL BE NON-COMBUSTIBLE MATERIAL

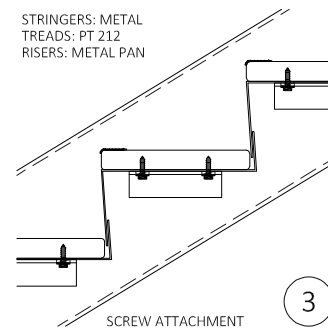

SCREW ATTACHMENT

3

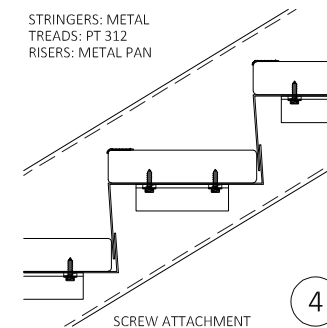

SCREW ATTACHMENT

4

METAL STAIR NOSINGS  
NON-SLIP CONTRASTING STRIPE  
MFG.: SAFE-T-NOSE  
PART #: STNR

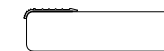

ADHESIVE ATTACHMENT  
AND/OR  
SCREW ATTACHMENT

A-A

**PERMA-TREAD™**

(971) 772-4553 | sales@nationalstair.com | www.nationalstair.com

BOLT TOGETHER METAL STAIR  
METAL FLAT PAN CLOSED RISERS



SCALE: N.T.S.

DWG #: PT-3.2