

* MUST REVIEW BUILDING TYPE FOR ACCEPTABLE STAIR FRAME CONSTRUCTION
 * MUST ENGINEER CONNECTIONS, STAIR FRAME, METAL PANS, LANDING FRAME TO MEET LOAD REQUIREMENTS

CLOSED RISER STAIR DESIGNS WITH PERMA-TREAD (PT)

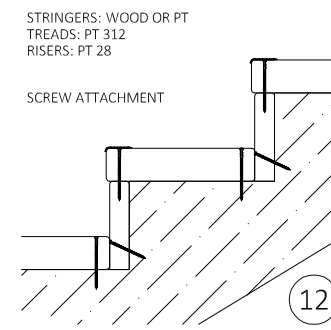

PAN FILLED STAIRS WITH PERMA-TREAD (PT)

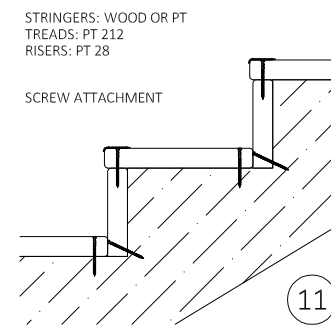
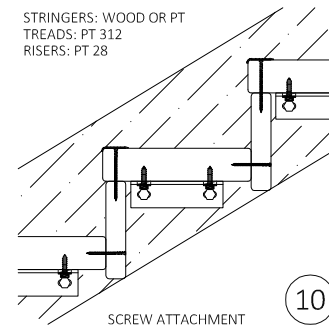
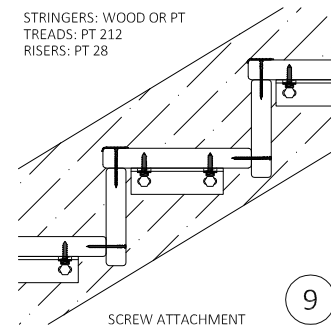
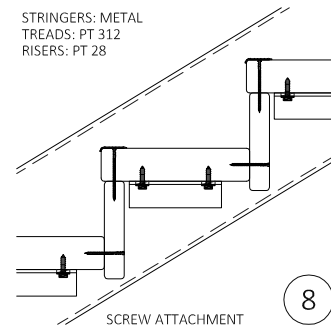
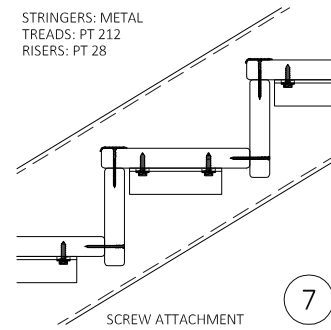
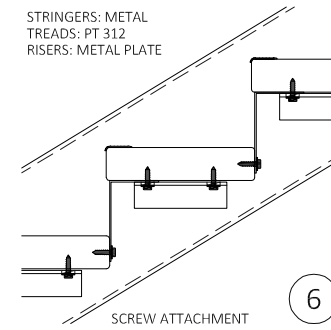
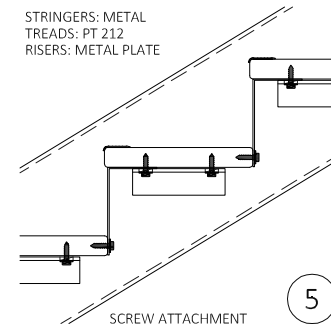
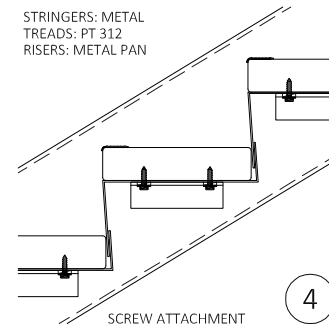
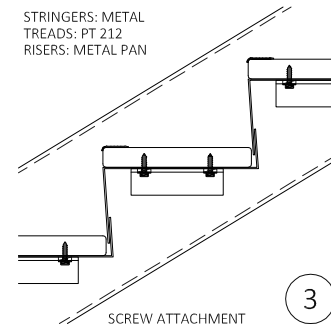
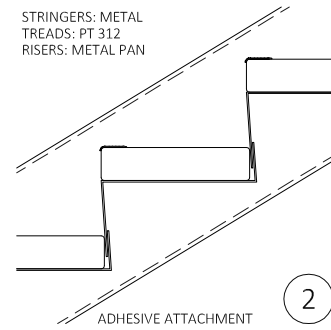
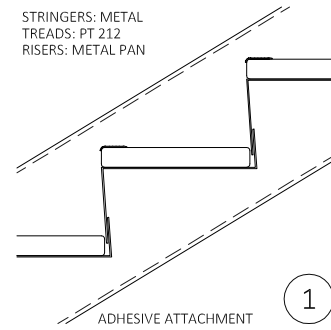
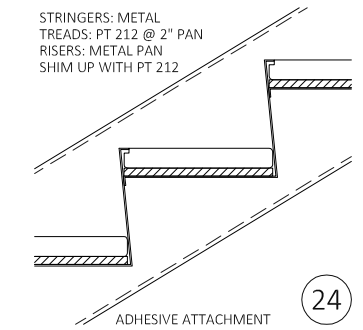
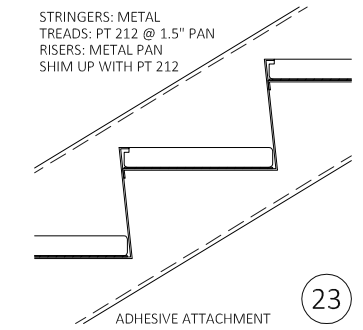

OPEN RISER STAIR DESIGNS WITH PERMA-TREAD (PT)

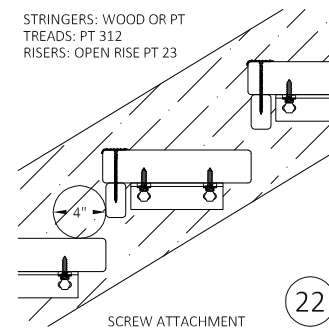
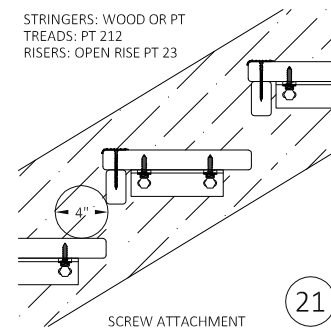
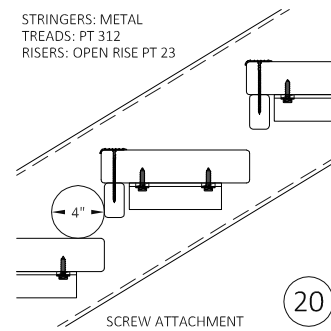
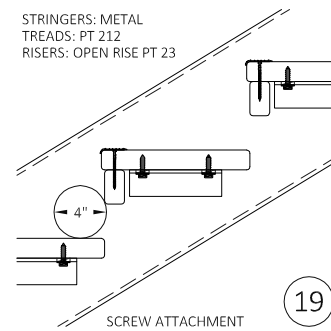
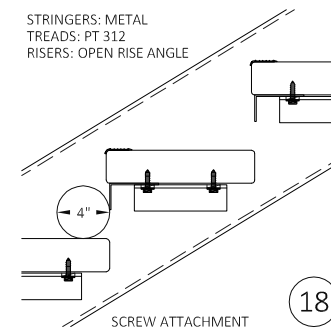
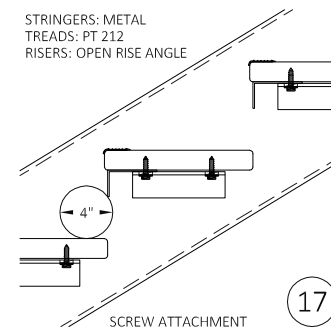
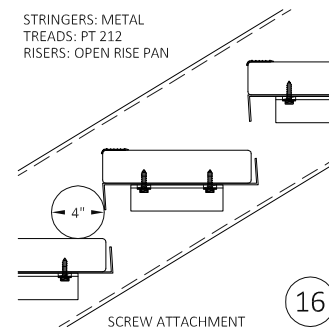
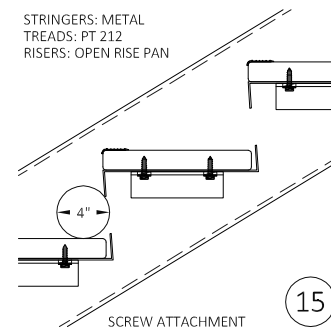
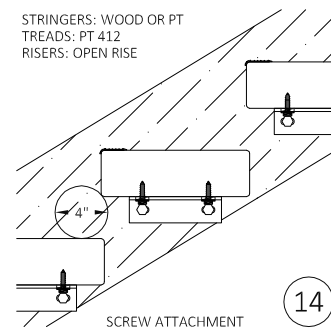
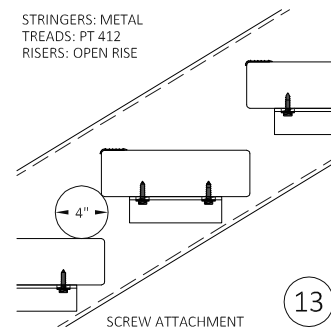

PERMA-TREAD™

(971) 772-4553 | sales@nationalstair.com | www.nationalstair.com

PERMA-TREAD
GENERAL STAIR DESIGN DETAILS



SCALE: N.T.S.

DWG #: PT-2.1